

Self Diagnosis
Supported model

SERVICE MANUAL

AE-6B CHASSIS

MODEL	COMMANDER	DEST	CHASSIS NO.	MODEL	COMMANDER	DEST	CHASSIS NO.
KV-29FX66E	RM-934	ESP	SCC-Q81B-A	KV-29FX66K	RM-934	OIRT	SCC-Q82A-A

FD Trinitron



KV-29FX66



RM-934

TRINITRON[®] COLOR TV
SONY[®]

TABLE OF CONTENTS

Section	Title	Page	Section	Title	Page
	Specifications	3			
	Connectors	4			
	Self Diagnostic Software	5			
1. GENERAL			5. DIAGRAMS		
	Switching On the TV and Automatically Tuning	6	5-1.	Block Diagrams (1)	23
	Introducing the Menu System	7		Block Diagrams (2)	24
	Menu Guide	7		Block Diagrams (3)	25
	Teletext	9		Block Diagrams (4)	26
	Remote Control Configuration for VCR/DVD	9	5-2.	Circuit Board Location	26
	Specifications	10	5-3.	Schematic Diagrams and Printed Wiring Boards	26
	Troubleshooting	10		* A Board Schematic	27
2. DISASSEMBLY				* A Board PWB	29
	2-1. Rear Cover Removal	11		* VM Board Schematic.....	33
	2-2. Speaker Disconnection	11		* VM Board PWB	31
	2-3. Chassis Removal	11		* H1 Board Schematic	33
	2-4. Service Position	12		* H1 Board PWB	34
	2-5. D and G Board Removal	12		* F4 Board Schematic	33
	2-6. F4 Bracket Removal	12		* F4 Board PWB	34
	2-7. F4 and H1 Board Removal	12		* H2 Board Schematic	33
	2-8. Side Control Module Removal	13		* H2 Board PWB	34
	2-9. H2 Board Removal	13		* G Board Schematic	35
	2-10. M Board Removal	13		* G Board PWB	34
	2-11. Service Connector for M Board.....	13		* D Board Schematic	36
	2-12. Picture Tube Removal	14		* D Board PWB	37
				* C Board Schematic	38
				* C Board PWB	39
				* M Board Schematic	40
				* M Board PWB	39
			5-4.	Semiconductors	41
3. SET-UP ADJUSTMENTS			5-5.	IC Blocks	44
	3-1. Beam Landing	16			
	3-2. Convergence	17	6. EXPLODED VIEWS		
	3-3. Focus Adjustment	19		6-1. Chassis	46
	3-4. Screen (G2), White Balance	19		6-2. Picture Tube	47
4. CIRCUIT ADJUSTMENTS			7. ELECTRICAL PARTS LIST		48
	4-1. Electrical Adjustments	20			
	4-2. Test Mode 2	22			

CAUTION

SHORT CIRCUIT THE ANODE OF THE PICTURE TUBE AND THE ANODE CAP TO THE METAL CHASSIS, CRT SHIELD, OR THE CARBON PAINTED ON THE CRT, AFTER REMOVAL OF THE ANODE CAP.

WARNING !!

AN ISOLATION TRANSFORMER SHOULD BE USED DURING ANY SERVICE WORK TO AVOID POSSIBLE SHOCK HAZARD DUE TO LIVE CHASSIS, THE CHASSIS OF THIS RECEIVER IS DIRECTLY CONNECTED TO THE POWER LINE.

SAFETY-RELATED COMPONENT WARNING !!

COMPONENTS IDENTIFIED BY SHADING AND MARKED Δ ON THE SCHEMATIC DIAGRAMS, EXPLODED VIEWS AND IN THE PARTS LIST ARE CRITICAL FOR SAFE OPERATION. REPLACE THESE COMPONENTS WITH SONY PARTS WHOSE PART NUMBERS APPEAR AS SHOWN IN THIS MANUAL OR IN SUPPLEMENTS PUBLISHED BY SONY.

ATTENTION

APRES AVOIR DECONNECTE LE CAP DE L'ANODE, COURT-CIRCUITER L'ANODE DU TUBE CATHODIQUE ET CELUI DE L'ANODE DU CAP AU CHASSIS METALLIQUE DE L'APPAREIL, OU AU COUCHE DE CARBONE PEINTE SUR LE TUBE CATHODIQUE OU AU BLINDAGE DU TUBE CATHODIQUE.

ATTENTION !!

AFIN D'EVITER TOUT RISQUE D'ELECTROCUTION PROVENANT D'UN CHÂSSIS SOUS TENTION, UN TRANSFORMATEUR D'ISOLEMENT DOIT ETRE UTILISÉ LORS DE TOUT DÉPANNAGE LE CHÂSSIS DE CE RÉCEPTEUR EST DIRECTMENT RACCORDÉ À L'ALIMENTATION SECTEUR.

ATTENTION AUX COMPOSANTS RELATIFS À LA SECURITÉ!!

LES COMPOSANTS IDENTIFIÉS PAR UNE TRAME ET PAR UNE MARQUE Δ SUR LES SCHÉMAS DE PRINCIPE, LES VUES EXPLOSÉES ET LES LISTES DE PIÈCES SONT D'UNE IMPORTANCE CRITIQUE POUR LA SÉCURITÉ DU FONCTIONNEMENT, NE LES REMPLACER QUE PAR DES COMPOSANTS SONY DONT LE NUMÉRO DE PIÈCE EST INDIQUÉ DANS LE PRÉSENT MANUEL OU DANS DES SUPPLÉMENTS PUBLIÉS PAR SONY.

ITEM MODEL	Television System	Stereo System	Channel Coverage	Color System
E	B/G/H	GERMAN/NICAM Stereo	VHF : E2-E12 UHF : E21-E69 CABLE TV : S01-S03, S1-S20	PAL, SECAM NTSC4.43, NTSC3.58 (VIDEO IN)
K	B/G/H, D/K	GERMAN/NICAM Stereo	VHF : E2-E12, R01-R12 UHF : E21-E69, R21-R69 CABLE TV : S01-S03, S1-S20	PAL, SECAM NTSC4.43, NTSC3.58 (VIDEO IN)

Picture Tube	FD Trinitron Approx 72 cm (29 inches) (Approx 68 cm picture measured diagonally) 104 degree deflection	Sound Output	
		Right and Left speaker	2x20W (Music Power) 2x10W (RMS)
		Subwoofer	1x30W (Music Power) 1x15W (RMS)
Input/Output Terminals [REAR]		General Specifications	
1: 21-pin Euro connector (CENELEC standard)	Inputs for Audio and Video signals. Inputs for RGB. Outputs of TV Video and Audio signals.	Power Requirements	220 - 240V
		Power Consumption	130W
2: 21-pin Euro connector	Inputs for Audio and Video signals. Inputs for S Video. Outputs of TV Video and Audio signals. (selectable)	Dimensions	Approx 771x585x506mm
		Weight	Approx 50kg
3: 21-pin Euro connector	Inputs for Audio and Video signals. Inputs for S Video. Outputs for Video and Audio signals (monitor out)	Supplied Accessories	RM-934 Remote Commander (1) IEC designated R6 battery (2)
Phono Jacks	Output Connectors variable for Audio Signals	Other Features	100 Hz picture, TV system Autodetection, Teletext, Smartlink, BBE, PIP, Virtual Dolby
Input/Output Terminals [SIDE]		Remote control system : Infrared control	
Headphone jack	stereo mini jack	Power requirements	3V dc 2 batteries IEC designation R6 (size AA)
Audio inputs	phono jacks		
Video inputs	phono jacks		
S Video input	4 pin DIN		
Design and specifications are subject to change without notice.			

Model Name Item	KV-29FX66E	KV-29FX66K
Pal Comb	OFF	OFF
PIP	ON	ON
RGB Priority	ON	ON
Woofer Box	ON	ON
Scart 1	ON	ON
Scart 2	ON	ON
Scart 3	ON	ON
Front in (4)	ON	ON
Projector	OFF	OFF
AKB in 16:9 mode	ON	ON
Norm B/G	ON	ON
Norm I	OFF	OFF
Norm D/K	OFF	ON
Norm AUS	OFF	OFF
Norm L	OFF	OFF
Norm SAT	OFF	OFF
Norm M	OFF	OFF
Teletext	ON	ON
Nicam Stereo	ON	ON

21 pin connector

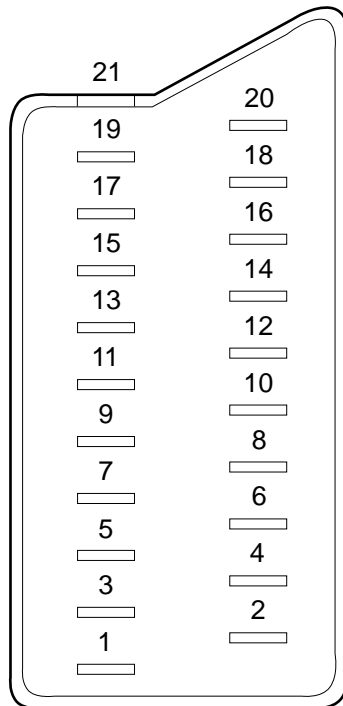

Pin No	1	2	3	Signal	Signal level
1	○	○	○	Audio output B (right)	Standard level : 0.5V rms Output impedance : Less than 1kohm*
2	○	○	○	Audio output B (right)	Standard level : 0.5V rms Output impedance : More than 10kohm*
3	○	○	○	Audio output A (left)	Standard level : 0.5V rms Output impedance : Less than 1kohm*
4	○	○	○	Ground (audio)	
5	○	○	○	Ground (blue)	
6	○	○	○	Audio input A (left)	Standard level : 0.5V rms Output impedance : More than 10kohm*
7	○	●	●	Blue input	0.7 +/- 3dB, 75 ohms positive
8	○	○	○	Function select (AV control)	High state (9.5-12V) : Part mode Low state (0-2V) : TV mode Input impedance : More than 10K ohms Input capacitance : Less than 2nF
9	○	○	○	Ground (green)	
10	○	○	○	Open	
11	○	●	●	Green	Green signal : 0.7 +/- 3dB, 75 ohms, positive
12	○	○	○	Open	
13	○	○	○	Ground (red)	
14	○	○	○	Ground (blanking)	
15	○	-	-	Red input	0.7 +/- 3dB, 75 ohms, positive
	-	○	○	(S signal Chroma input)	0.3 +/- 3dB, 75 ohms, positive
16	○	●	●	Blanking input (Ys signal)	High state (1-3V) Low state (0-0.4V) Input impedance : 75 ohms
17	○	○	○	Ground (video output)	
18	○	○	○	Ground (video input)	
19	○	○	○	Video output	1V +/- 3dB, 75ohms, positive sync 0.3V (-3+10dB)
20	○	-	-	Video input	1V +/- 3dB, 75ohms, positive sync 0.3V (-3+10dB)
	-	○	○	Video input Y (S signal)	1V +/- 3dB, 75ohms, positive sync 0.3V (-3+10dB)
21	○	○	○	Common ground (plug, shield)	

○ Connected ● Not Connected (open) * at 20Hz - 20kHz

Rear Connection Panel

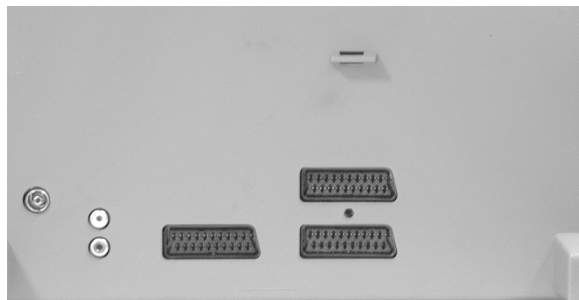

Front Connection Panel

S-Video socket



S Video socket pin configuration		
Pin No	Signal	Signal Level
1	Ground	-
2	Ground	-
3	Y (S signal) input	1V +/- 3dB 75ohm, positive Sync. 0.3V -3 +10dB
4	C (S signal) input	0.3V +/- 3dB 75ohm, positive Sync.

AE-6B SELF DIAGNOSTIC SOFTWARE

The identification of errors within the AE-6B chassis is triggered in one of two ways :- 1: Busy or 2: Device failure to respond to IIC. In the event of one of these situations arising the software will first try to release the bus if busy (Failure to do so will report with a continuous flashing LED) and then communicate with each device in turn to establish if a device is faulty. If a device is found to be faulty the relevant device number will be displayed through the LED (Series of flashes which must be counted) See table 1., non fatal errors are reported using this method.

Each time the software detects an error it is stored within the NVM. See Table 2.

Table 1

Error Message	LED Code
No error	00
Reserved	01
OCB (Over Current Protection)	02
Over Voltage Protection	03
No Vertical Sync	04
IKR Error at power on	05
IIC bus clock and/or data lines low at power on	06
NVM no IIC bus acknowledge at power on	07
Horizontal Protection	08
Tuner no acknowledge at power on	09
Sound Processor Error	10
Reserved	11
Scanrate Error	12
DAC Error	13
Backend Error	14
Dynamic Convergence Error	15
PIP Error	16

Flash Timing Example : e.g. error number 3

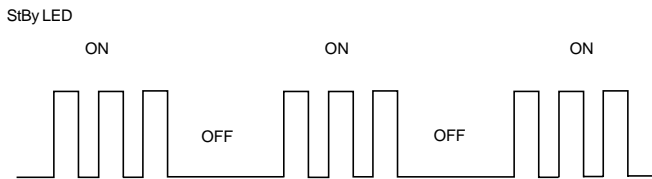

How to enter into Table 2

1. Turn on the main power switch of the TV set.
2. Program Remote Commander for Operation in Service Mode. [See Page 20].
2. Press 'VIDEO' 'VIDEO' > 'MENU' > ERROR MENU on the Remote Commander.
3. The following table will be displayed indicating the error count.

Table 2

ERROR MENU			
E02	OCB	(0, 255)	0
E03	OVP	(0, 255)	0
E04	VSYNC	(0, 255)	0
E05	IKR	(0, 255)	0
E06	IIC	(0, 255)	0
E07	NVM	(0, 255)	0
E08	HPROT	(0, 255)	0
E09	TUNER	(0, 255)	0
E10	SOUNDP	(0, 255)	0
E11	-	(0, 255)	0
E12	SCANRATE	(0, 255)	0
E13	DAC	(0, 255)	0
E14	BACKEND	(0, 255)	0
E15	DYN CON	(0, 255)	0
E16	PIP	(0, 255)	0
WORKING TIME			
HOURS			14
MINUTES			7

Note: To clear the error count data press '80' on the Remote commander.

SECTION 4 CIRCUIT ADJUSTMENTS

4-1. Electrical Adjustments

Service adjustments to this model can be performed using the supplied remote Commander RM-934.

Programming the Remote Commander for Operation in Service Mode

1. Press the VCR/TV/DVD button until the TV LED lights.
2. Press and hold the yellow button for approx. 5 seconds until the TV LED flashes quickly.
3. Press 99999. All three LED's should light. The remote commander is now set to Service Mode.
4. To return the remote commander to normal operation mode repeat steps 1. and 2. then press 00000. All three LED's should light. The remote commander is now set to normal mode.



Setting the TV into Service Mode

1. Program the remote commander for operation in Service Mode as described above.
2. Turn on the TV main power switch.
3. Press the video standby button  on the remote commander twice. 'TT __' will appear in the upper right corner of the screen. Other status information will also be displayed.
4. Press 'MENU' on the remote commander to obtain the following menu on the screen.

Geometry
 Service
 Scanrate
 DAC
 Dyn. Conv.
PiP
 Sound
 IF adjust
 Error Menu

AE6B v0.14 (Jun 2001)
 Factory data FFh FFh
 MSP Device : MSP3411G

5. Move to the corresponding adjustment item using the up or down arrow buttons on the Remote Commander.
6. Press the right arrow button to enter into the required menu item.
7. Press the 'Menu' button on the Remote Commander to quit the Service Mode when all adjustments have been completed.

Note :

- After carrying out the service adjustments, to prevent the customer accessing the 'Service Menu' switch the TV set OFF and then ON.

GEOMETRY		
ABL TH	(0, 3)	0
ABL MODE	(0, 3)	0
P ABL	(0, 15)	15
V SIZE	(0, 63)	35
V POSITION	(0, 63)	33
V COMP	(0, 3)	1
V LIN	(0, 15)	7
S CORRECTION	(0, 15)	7
H SIZE	(0, 63)	44
PIN AMP	(0, 63)	32
UP CORNERPIN	(0, 63)	29
M PIN	(0, 3)	2
LO CORNERPIN	(0, 63)	29
TRAPEZIUM	(0, 15)	2
H POSITION	(0, 63)	40
AFC BOW	(0, 15)	8
AFC ANGLE	(0, 15)	9
LEFT BLK	(0, 63)	34
RIGHT BLK	(0, 63)	17
V ASPECT	(0, 63)	47
AKBTIM1	(0, 3)	2
AKBTIM2	(0, 1)	0
IKR		1
HNG		0
VNG		0

DYN. CONV.		
RANGE	(0, 63)	63
YupL	(0, 1)	0
VAL	(0, 63)	30
YlowL	(0, 1)	0
VAL	(0, 63)	31
MBOWupL	(0, 1)	0
VAL	(0, 63)	31
MBOWlowL	(0, 1)	0
VAL	(0, 63)	32
HAMPL	(0, 1)	0
VAL	(0, 63)	37
YupR	(0, 1)	0
VAL	(0, 63)	30
YlowR	(0, 1)	0
VAL	(0, 63)	30
MBOWupR	(0, 1)	0
VAL	(0, 63)	32
MBOWlowR	(0, 1)	0
VAL	(0, 63)	32
HAMPR	(0, 1)	0
VAL	(0, 63)	36
UP Y	(0, 1)	0
VAL	(0, 63)	31
LOW Y	(0, 1)	0
VAL	(0, 63)	33
H STAT	(0, 1)	0
VAL	(0, 63)	33
UP CORR	(0, 1)	0
VAL	(0, 63)	34
LOW CORR	(0, 1)	0
VAL	(0, 63)	19

IF ADJUST		
Automute		1
Audio Gain		0
L Gating		0

SERVICE		
SUB COL	(0, 63)	Adj
SUB HUE	(0, 63)	31
SUB SHARP	(0, 63)	30
SUB BRIGHT	(0, 63)	13
SUB CONT	(0, 15)	12
R-DRIVE	(0, 63)	50
G-DRIVE	(0, 63)	Adj
B-DRIVE	(0, 63)	Adj
R CUTOFF	(0, 63)	28
G CUTOFF	(0, 63)	24
B CUTOFF	(0, 63)	46
Br TXT	(0, 15)	7
Br OSD	(0, 15)	10

DAC			
CONFIG		00000000	
MPIN CONT	(0, 255)		96
HLIN	(0, 255)		83
HTRAP	(0, 255)		127
ROT. COIL	(0, 255)		130
PHOCUS PH	(0, 255)		90

SOUND			
M-N	(0, 511)		200
M-D	(-128, -1)		-20
M-S	(+0, +127)		+20
S-M	(+0, +127)		+10
D-M	(-128, -1)		-10
N-M	(0, 1023)		496
BBE	(+0, +68)		+28
B1	(-96, +96)		+0
B2	(-96, +96)		+0
B3	(-96, +96)		+0
B4	(-96, +96)		+0
B5	(-96, +96)		+0
SW L	(-128, +0)		+0
SW F	(+5, +40)		+30
NICAM C AD		10001	
NICAM Error	(0, 2047)		0
Stereo	(-128, +127)		+0
Status		000000110	

ERROR MENU			
E02	OCP	(0, 255)	0
E03	OVP	(0, 255)	0
E04	VSUNC	(0, 255)	0
E05	IKR	(0, 255)	0
E06	IIC	(0, 255)	0
E07	NVM	(0, 255)	0
E08	HPROT	(0, 255)	0
E09	TUNER	(0, 255)	0
E10	SOUNDP	(0, 255)	0
E11	-	(0, 255)	0
E12	SCANRATE	(0, 255)	0
E13	DAC	(0, 255)	0
E14	BACKEND	(0, 255)	0
E15	DYN CON	(0, 255)	0
E16	PIP	(0, 255)	0
WORKING TIME			
HOURS			14
MINUTES			7

Sub Brightness Adjustment

1. Input a Monoscope pattern.
2. Program the Remote Commander for operation in Service Mode. [See Page 20].
3. Press 'VIDEO' 'VIDEO' 13 on the Remote Commander.
4. Adjust the 'Sub-Brightness' data so that there is barely a difference between the 0 IRE and 10 IRE signal levels.

Sub Contrast Adjustment

1. Input a video signal that contains a small 100% white area on a black background.
2. Connect an digital voltmeter to Pin 10 of J7378 [C Board].
3. Program the Remote Commander for operation in Service Mode. [See Page 20].
4. Adjust the Sub-Contrast [Using 'VIDEO' 'VIDEO' '11'] to obtain a voltage of 105 +/- 5V.

Sub Colour Adjustment

1. Receive a PAL colour bar signal.
2. Connect an oscilloscope to Pin 6 of CN7001 [A Board].
3. Program the Remote Commander for operation in Service Mode. [See Page 20].
4. Adjust the 'Sub Colour' [Using 'VIDEO' 'VIDEO' '12'] so that the Cyan, Magenta and Blue colour bars are of equal levels as indicated below.

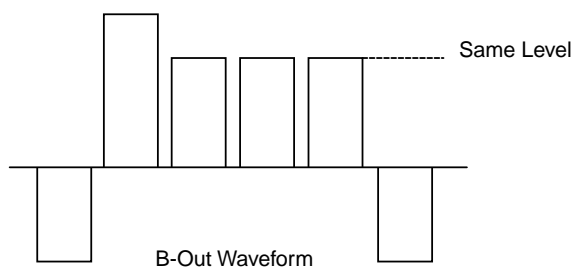

Deflection System Adjustment

1. Program the Remote Commander for operation in Service Mode. [See Page 20] and enter into the 'Geometry' service menu.
2. Select and adjust each item in order to obtain the optimum image.

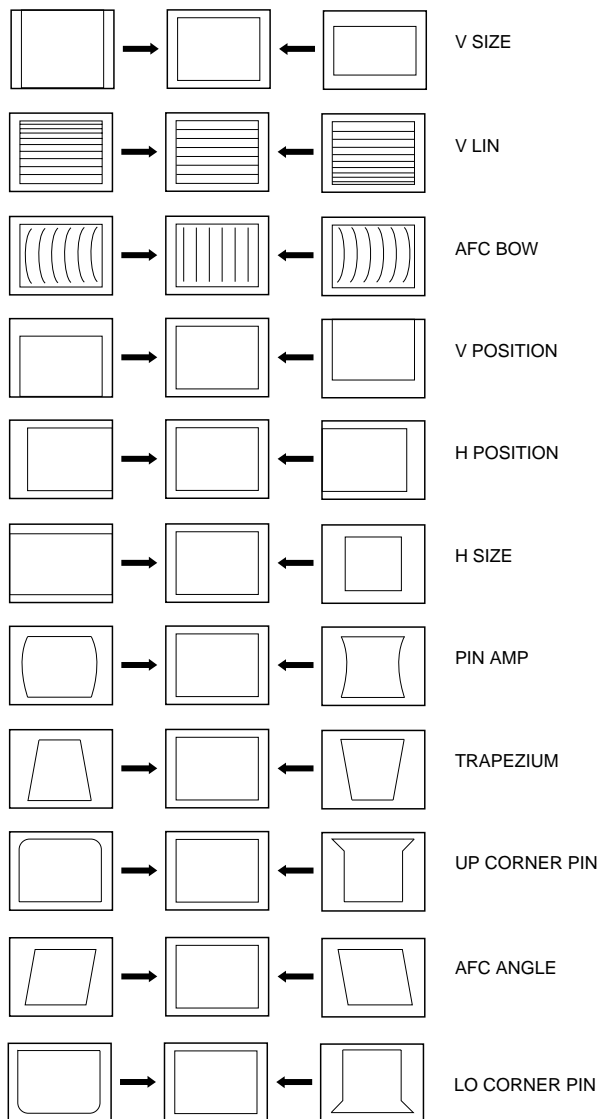

GEOMETRY		
ABL TH	(0, 3)	0
ABL MODE	(0, 3)	0
P ABL	(0, 15)	15
V SIZE	(0, 63)	35
V POSITION	(0, 63)	33
V COMP	(0, 3)	1
V LIN	(0, 15)	7
S CORRECTION	(0, 15)	7
H SIZE	(0, 63)	44
PIN AMP	(0, 63)	32
UP CORNERPIN	(0, 63)	29
M PIN	(0, 3)	2
LO CORNERPIN	(0, 63)	29
TRAPEZIUM	(0, 15)	2
H POSITION	(0, 63)	40
AFC BOW	(0, 15)	8
AFC ANGLE	(0, 15)	9
LEFT BLK	(0, 63)	34
RIGHT BLK	(0, 63)	17
V ASPECT	(0, 63)	47
AKBTIM1	(0, 3)	2
AKBTIM2	(0, 1)	0
IKR		1
HNG		0
VNG		0

4-3. TEST MODE 2:

Test Mode 2 is available by programming the Remote Commander for operation in Service Mode [As shown on Page 20] then pressing the 'VIDEO' button twice, OSD 'TT' appears. The functions described below are available by selecting the two numbers. To release the 'Test mode 2', press 00, 10, 20 ... twice or switch the TV set into Stand-by mode. In 'TT Menu' mode, it is possible to remove the Menu from the screen by pressing the Speaker Off button once. Pressing the Speaker OFF button a second time will cause the Menu to reappear. The function is kept even when the menu is not displayed on screen !!.

00	'TT' mode off
01	Picture maximum
02	Picture minimum
03	Set speaker/headphone Volume to 35%
04	Set speaker/headphone Volume to 50%
05	Set speaker/headphone Volume to 65%
06	Set speaker/headphone Volume to 80%
07	Ageing mode
08	Shipping Condition
11	Sub picture adjustment
12	Sub colour adjustment
13	Sub Brightness adjustment
14	Text H Position adjustment
15	Rotation Coil Test
16	Picture level 50%
19	Factory Mode Enable/Disable
21	Destination ADEKR
22	Destination BL
23	Destination ADEKR
24	Destination U
25	Destination ADEKR
26	Destination BL
27	Destination ADEKR
28	Destination ADEKR
31	Auto Shutoff Enable/Disable
36	Velocity Modulation (VM) OFF/ON test
41	Re-initialise NVM
43	Select Dual A sound
44	Select Dual B sound
45	Select Mono sound
46	Select Stereo sound
48	Set NVM as non virgin
49	Set NVM as virgin
53	FM Overmodulation Enable/Disable
55	Tuner selection (SONY/ALPS)
59	Select Model 3 Scarts + PIP or 2 Scarts
68	Enable/Disable X26 countermeasure (N problem)
73	Enable Zweiton D/K2 system (6.5/6.74)
74	Enable Zweiton D/K3 system (6.5/5.74)
78	Balance full right
79	Balance full left
87	Local keys test
99	Display Error and Working Time menu

5-1. BLOCK DIAGRAMS (1)

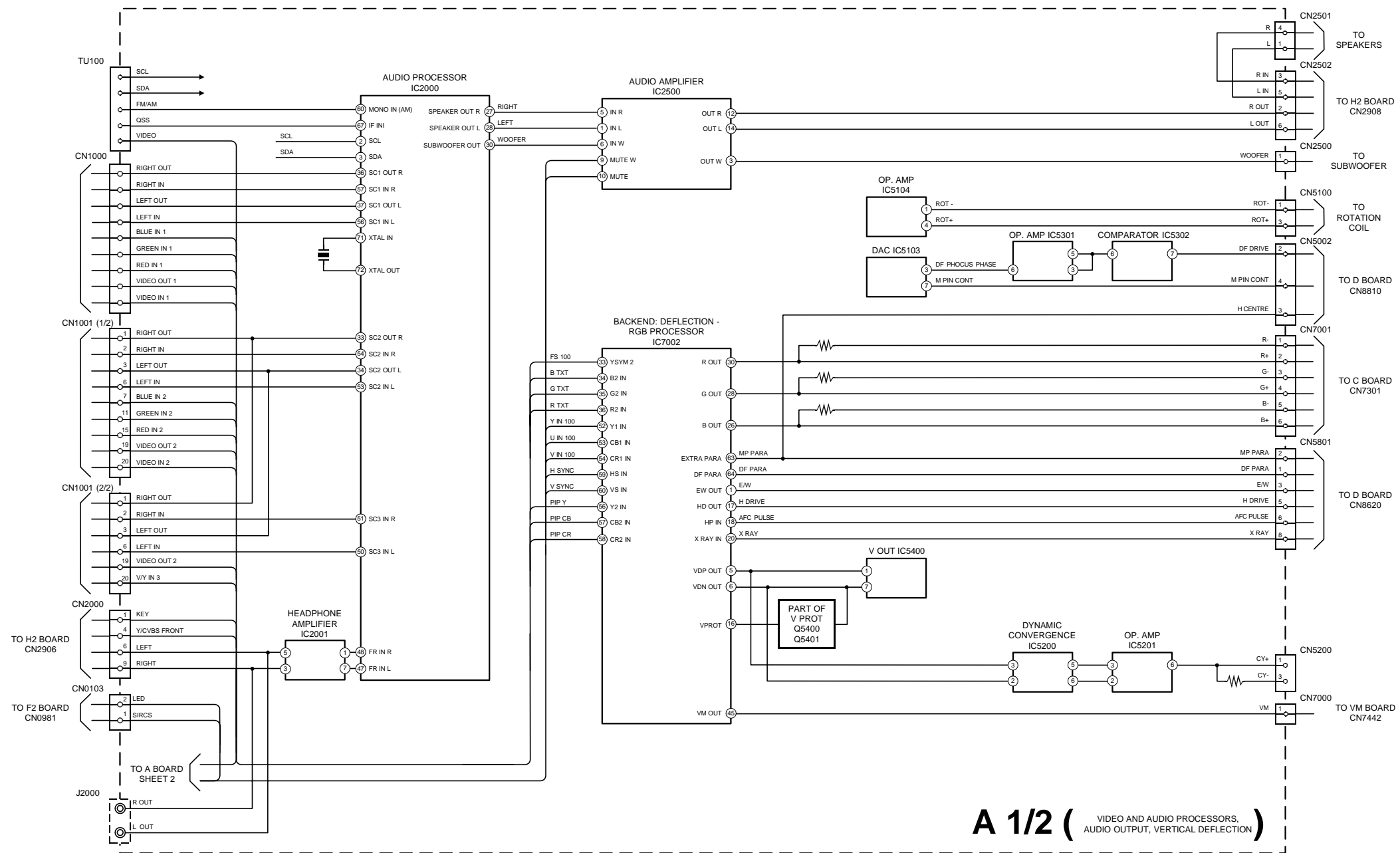
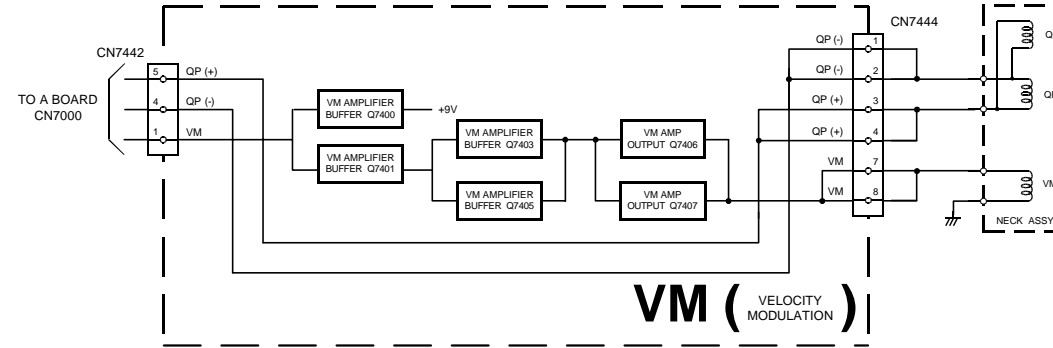

5-1. BLOCK DIAGRAMS (2)

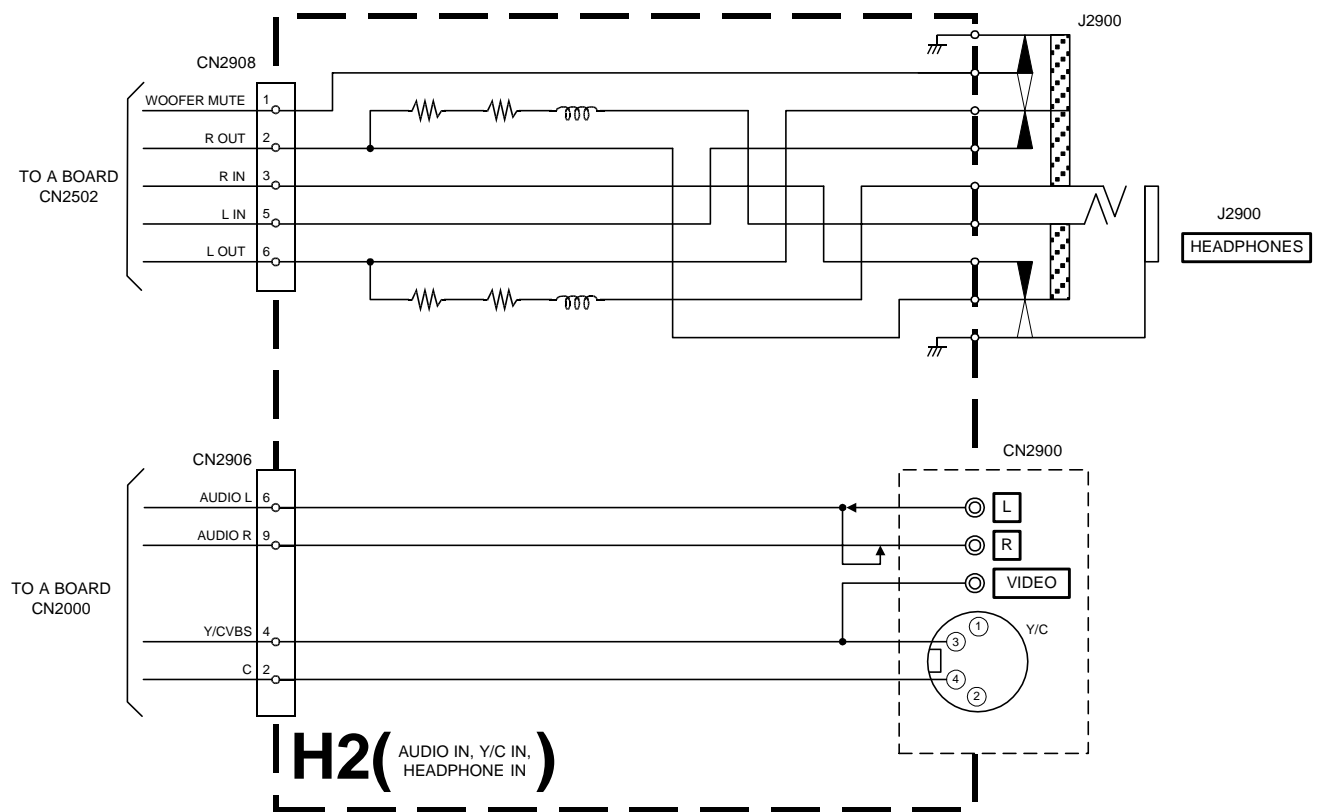
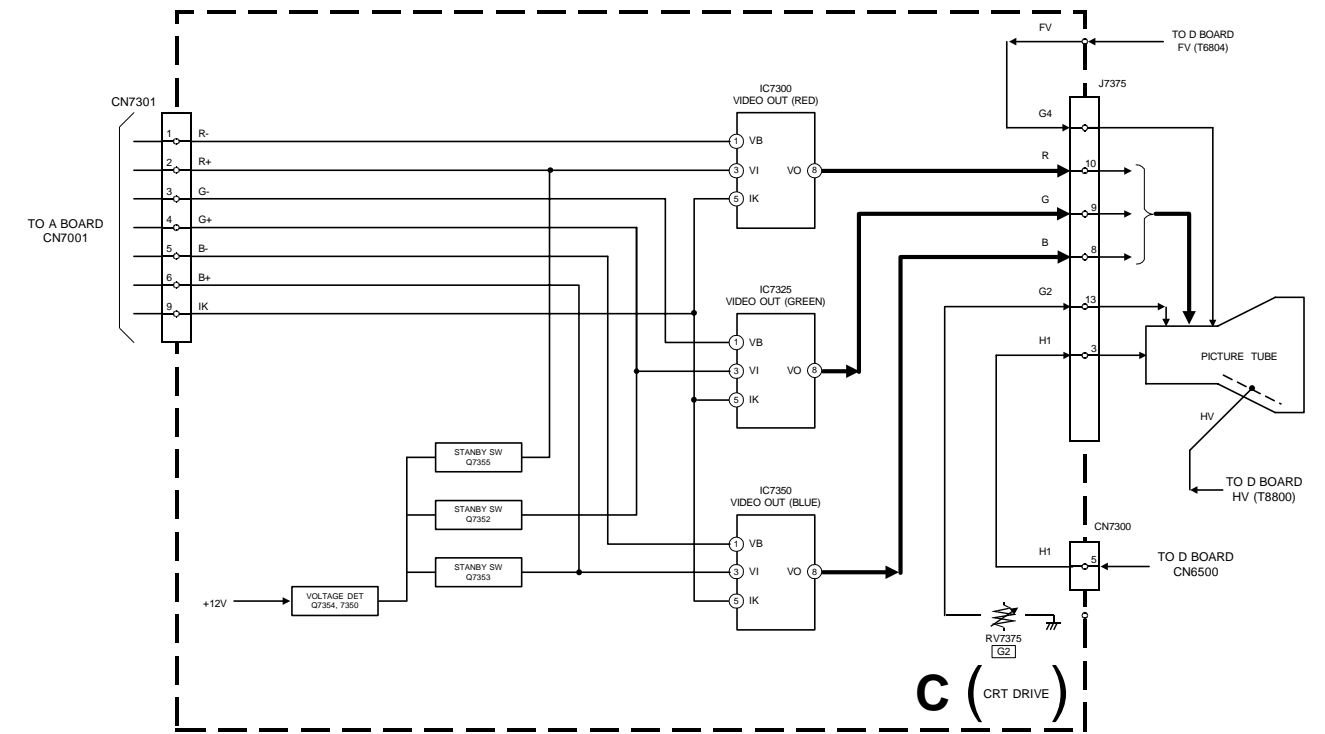
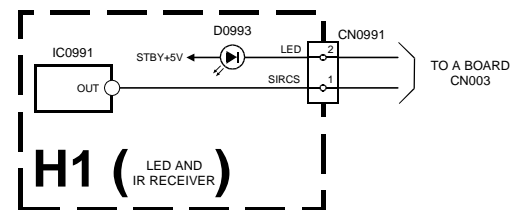
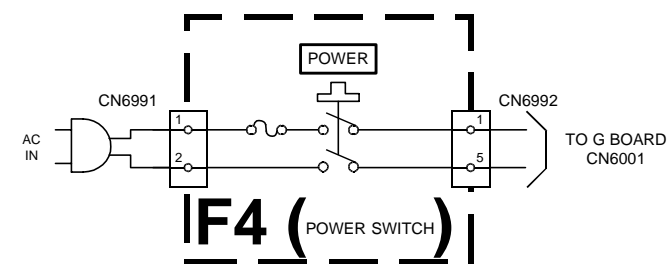
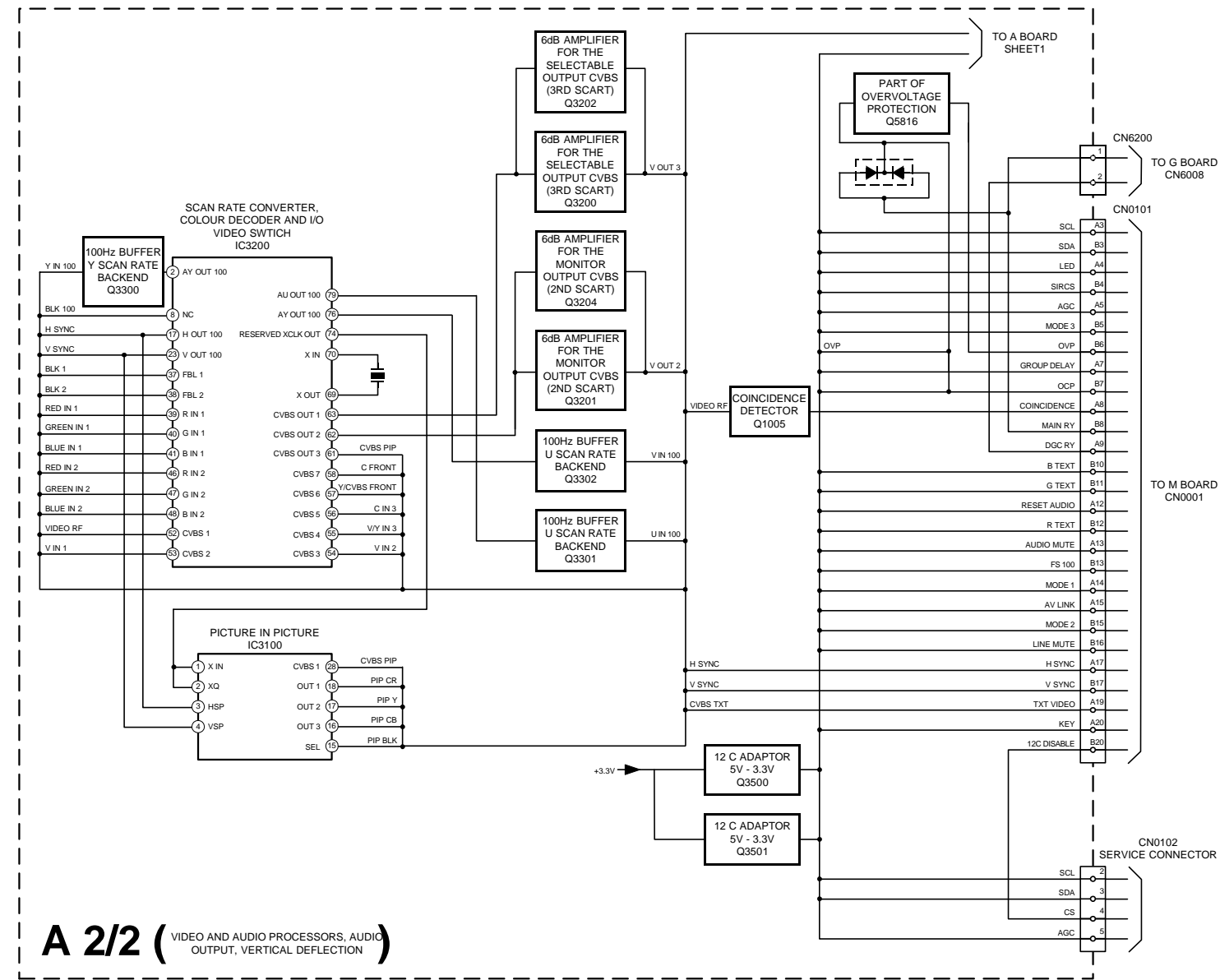

5-1. BLOCK DIAGRAMS (3)

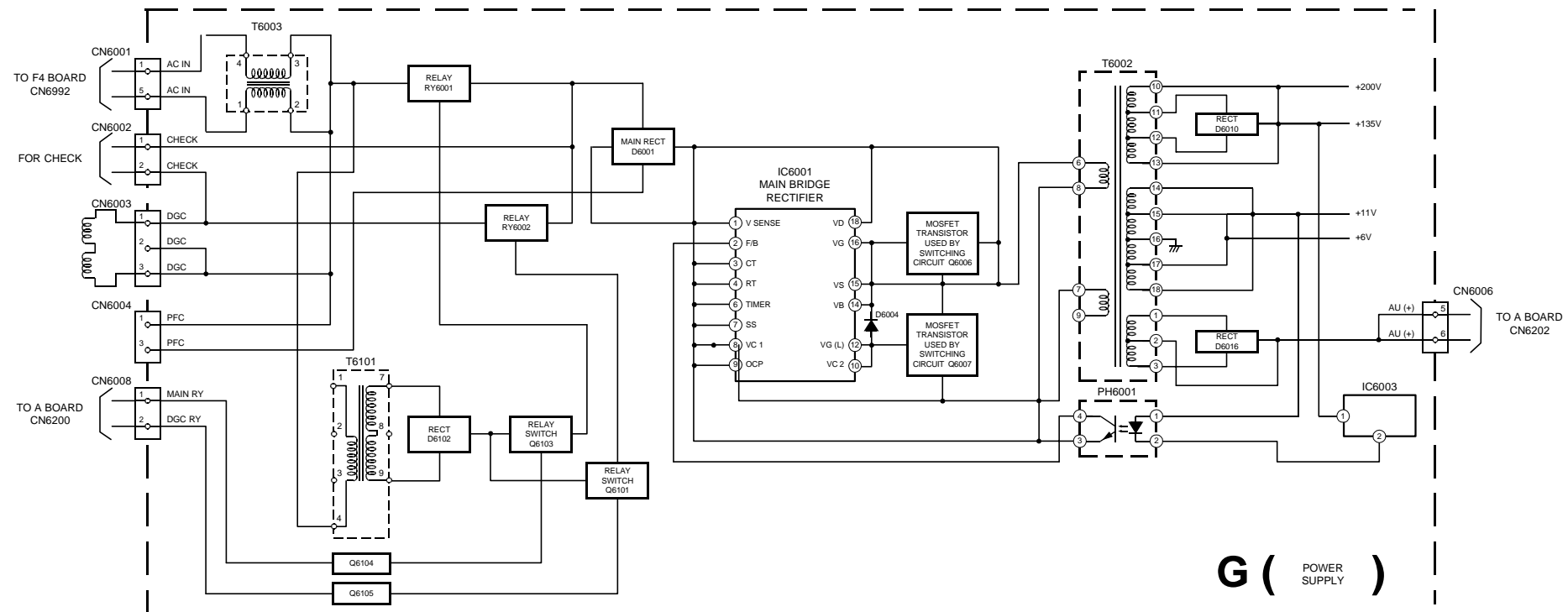
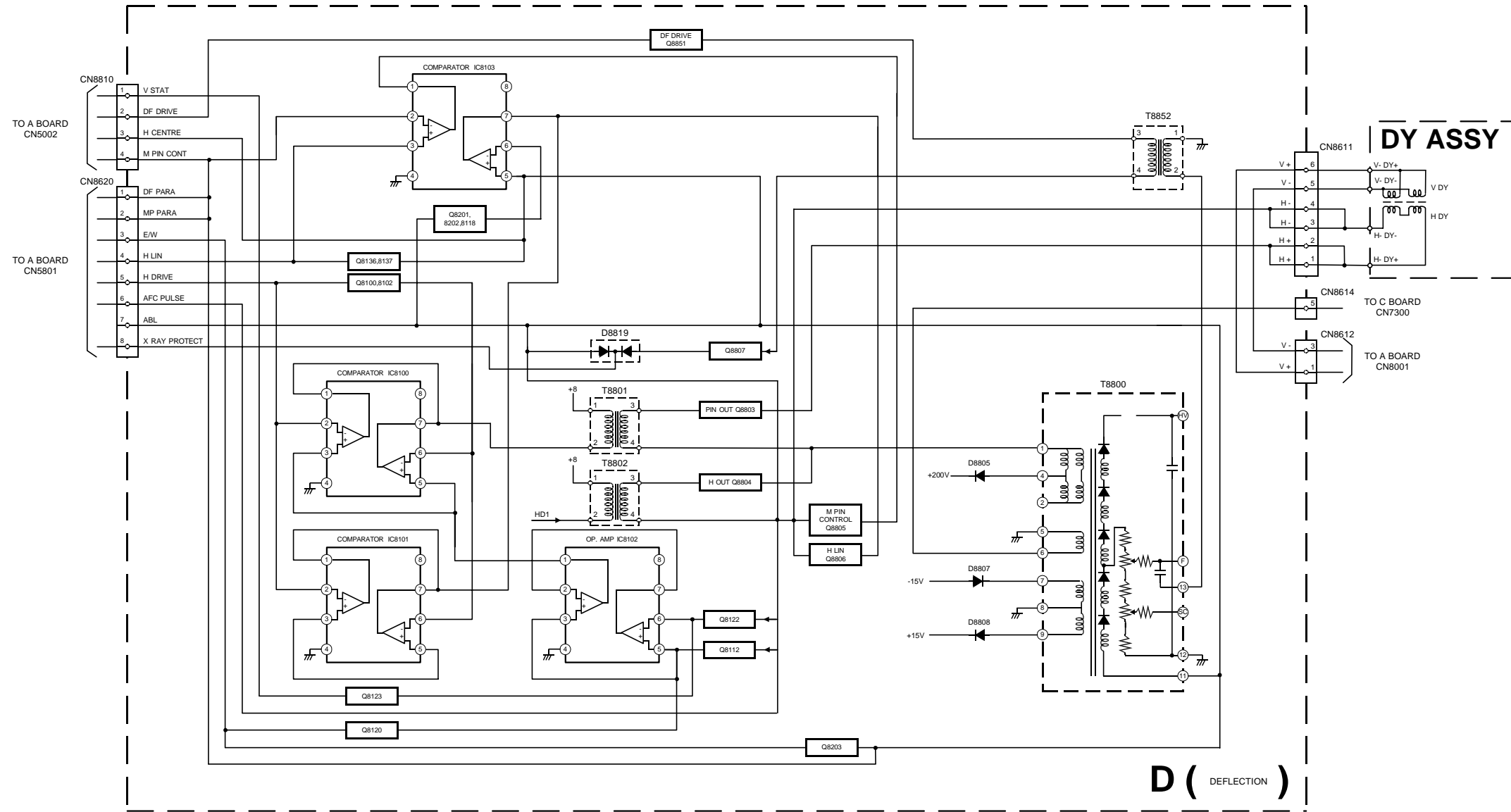

5-1. BLOCK DIAGRAMS (4)

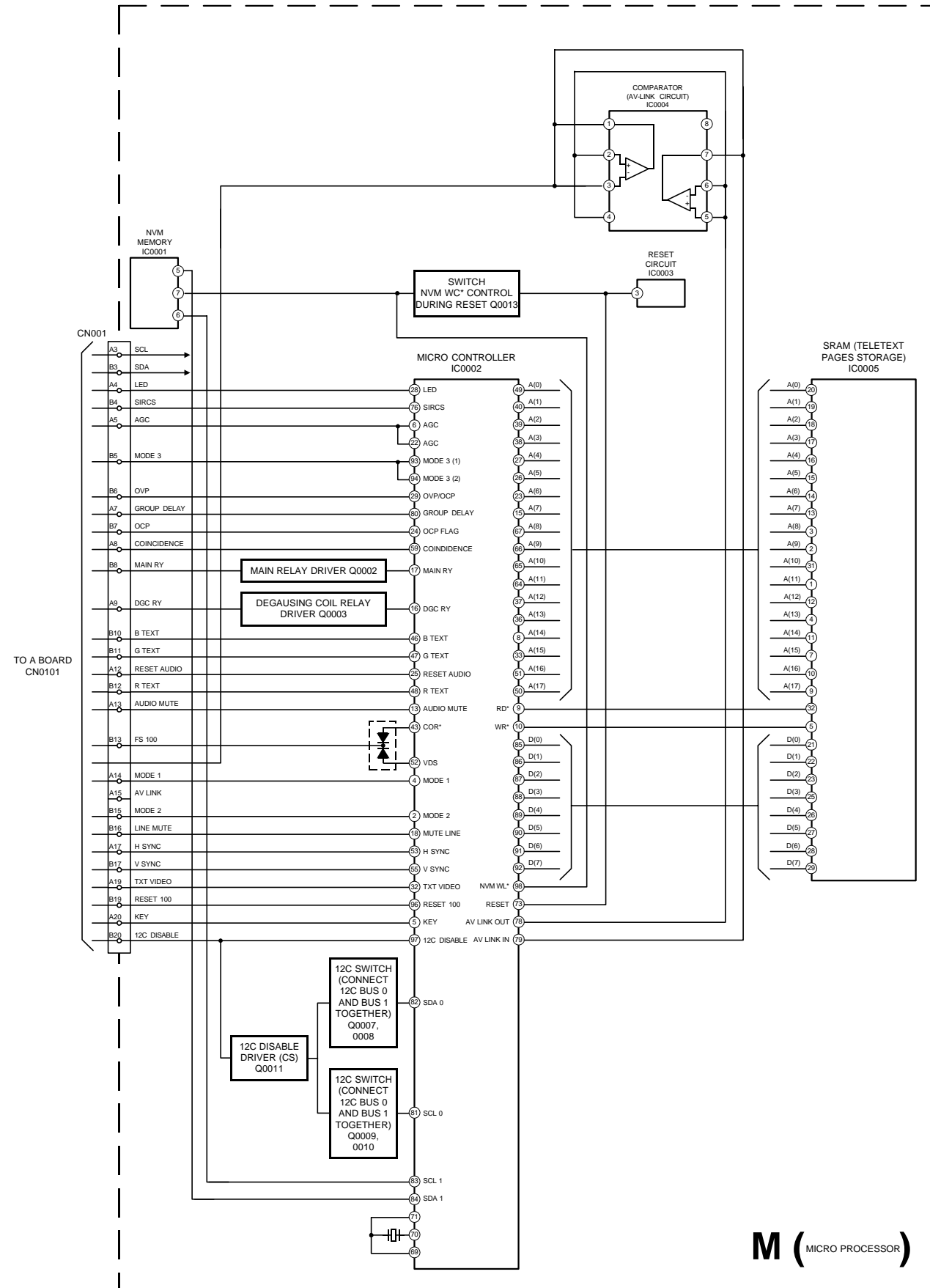

5-2. CIRCUIT BOARD LOCATION

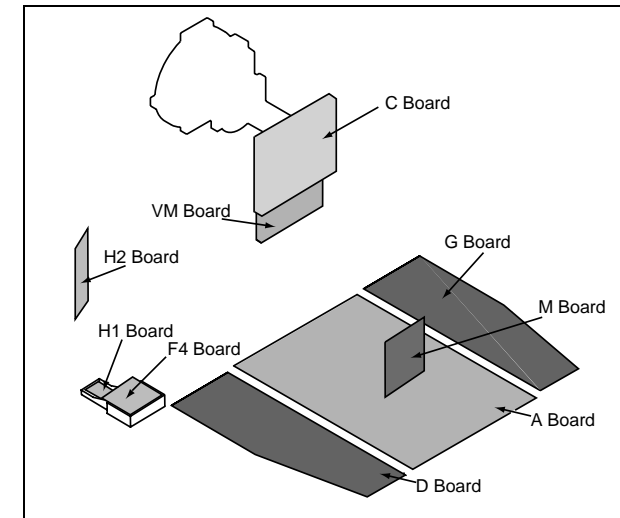

5-3. SCHEMATIC DIAGRAMS AND PRINTED WIRING BOARDS

Note :

- All capacitors are in μF unless otherwise noted.
- pF : μF 50WV or less are not indicated except for electrolytic types.
- Indication of resistance, which does not have one for rating electrical power, is as follows.

Pitch : 5mm
Electrical power rating : 1/4W

- Chip resistors are 1/10W
- All resistors are in ohms.
 $k = 1000$ ohms, $M = 1000,000$ ohms
- : nonflammable resistor.
- : fusible resistor.
- : internal component.
- : panel designation or adjustment for repair.
- All variable and adjustable resistors have characteristic curve B, unless otherwise noted.
- All voltages are in Volts.
- Readings are taken with a 10Mohm digital mutimeter.
- Readings are taken with a color bar input signal.
- Voltage variations may be noted due to normal production tolerances.

- : B - bus.
- : RF signal path.
- : earth - ground.
- : earth - chassis.

Reference Information

RESISTOR	RN	: METAL FILM
	RC	: SOLID
	FPRD	: NON FLAMMABLE CARBON
	FUSE	: NON FLAMMABLE FUSIBLE
	RS	: NON FLAMMABLE METAL OXIDE
	RB	: NON FLAMMABLE CEMENT
	RW	: NON FLAMMABLE WIREWOUND
		: ADJUSTMENT RESISTOR
COIL	LF-8L	: MICRO INDUCTOR
CAPACITOR	TA	: TANTALUM
	PS	: STYROL
	PP	: POLYPROPYLENE
	PT	: MYLAR
	MPS	: METALIZED POLYESTER
	MPP	: METALIZED POLYPROPYLENE
	ALB	: BIPOLAR
	ALT	: HIGH TEMPERATURE
	ALR	: HIGH RIPPLE

Note : The components identified by shading and marked Δ are critical for safety. Replace only with the part numbers specified in the parts list.

Note : Les composants identifiés par une trame et par une marque Δ sont d'une importance critique pour la sécurité. Ne les remplacer que par des pièces de numéro spécifié.

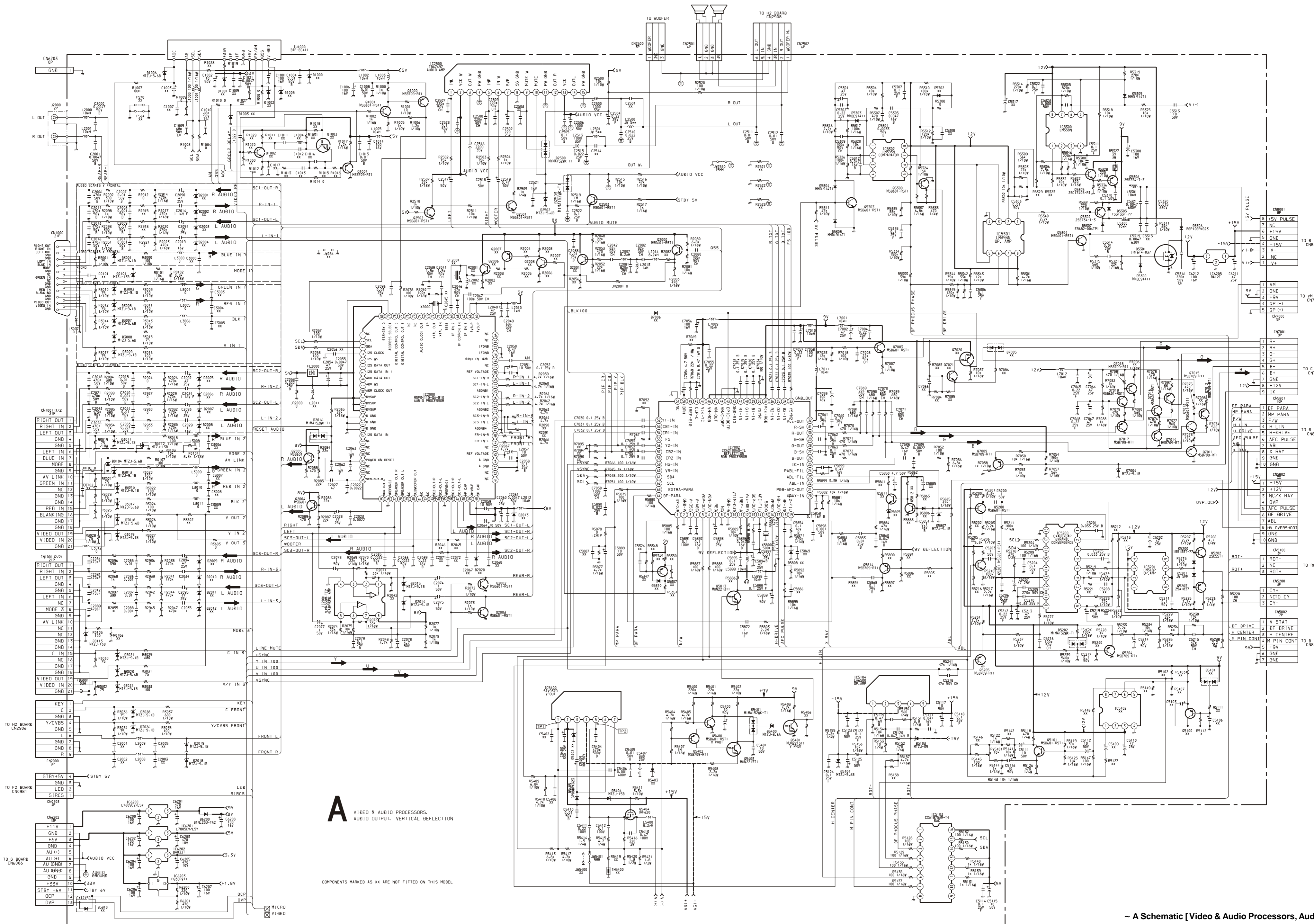

A VIDEO & AUDIO PROCESSORS.
AUDIO OUTPUT, VERTICAL DEFLECTION

COMPONENTS MARKED AS XX ARE NOT FITTED ON THIS MODEL

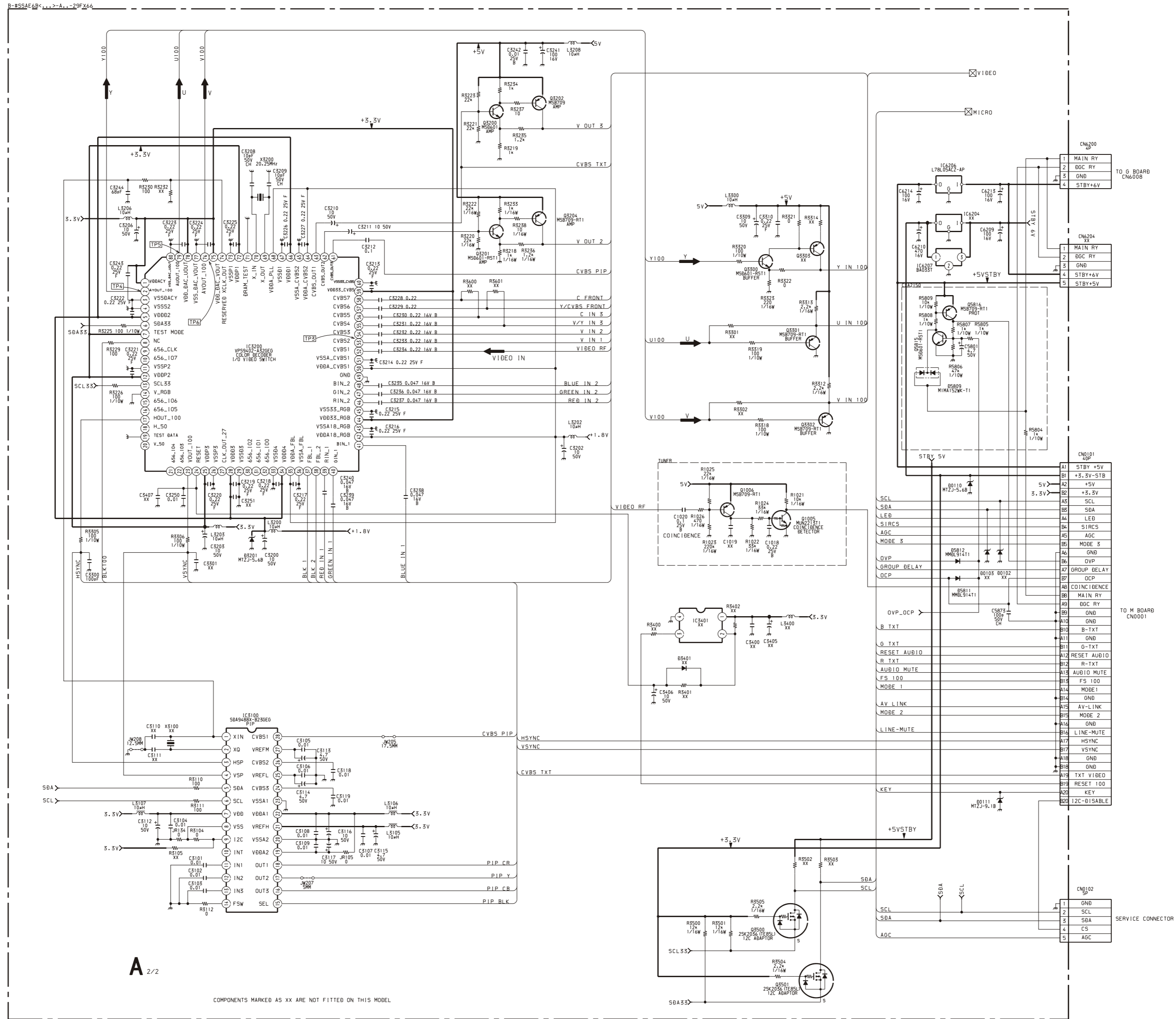

A 2/2

~ H1 Board Schematic Diagram ~

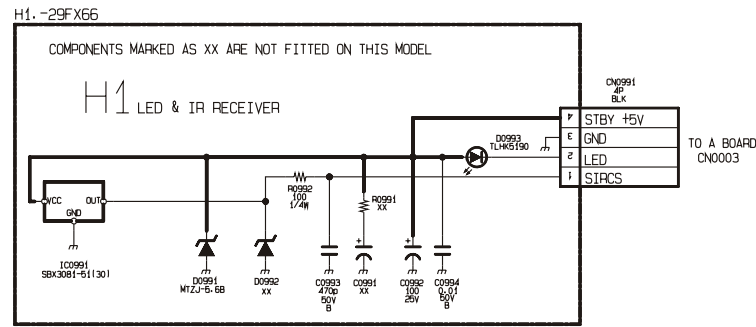

~ H2 Board Schematic Diagram ~

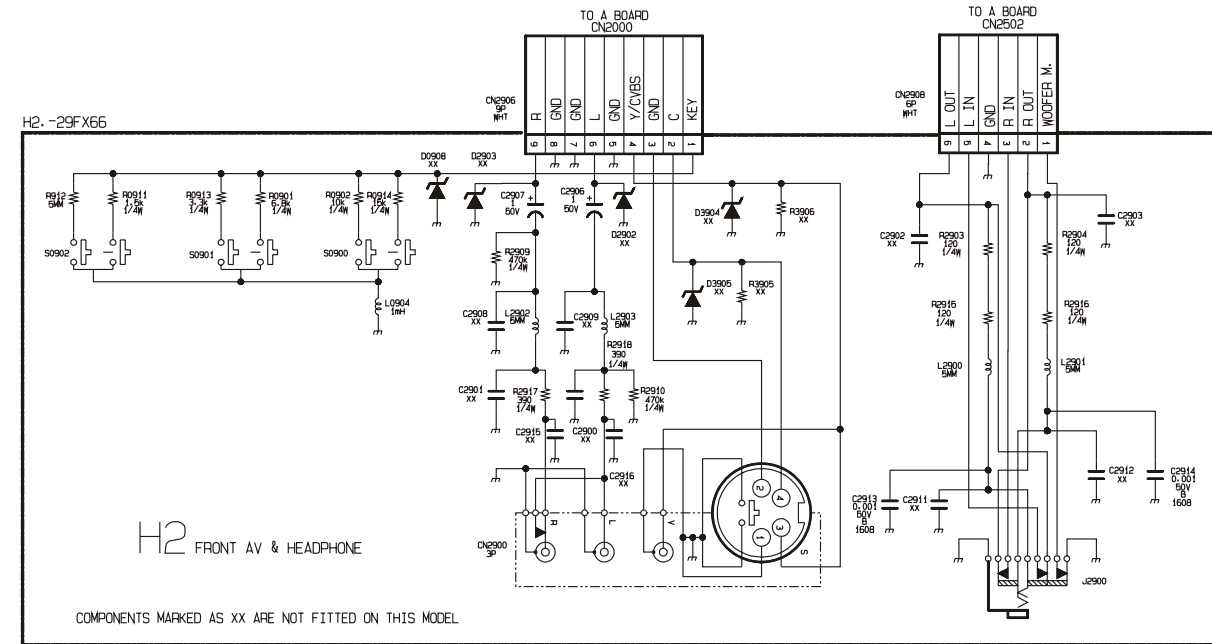

~ F4 Board Schematic Diagram ~

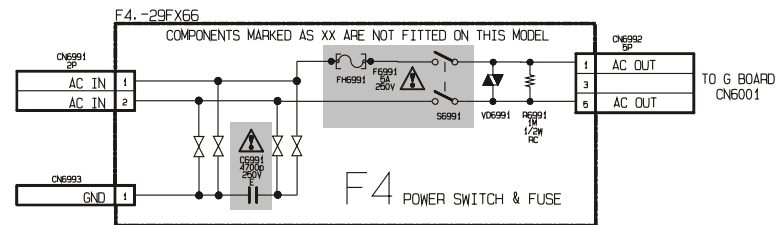

B-#SSAE6B<...>-VM.-29FX66

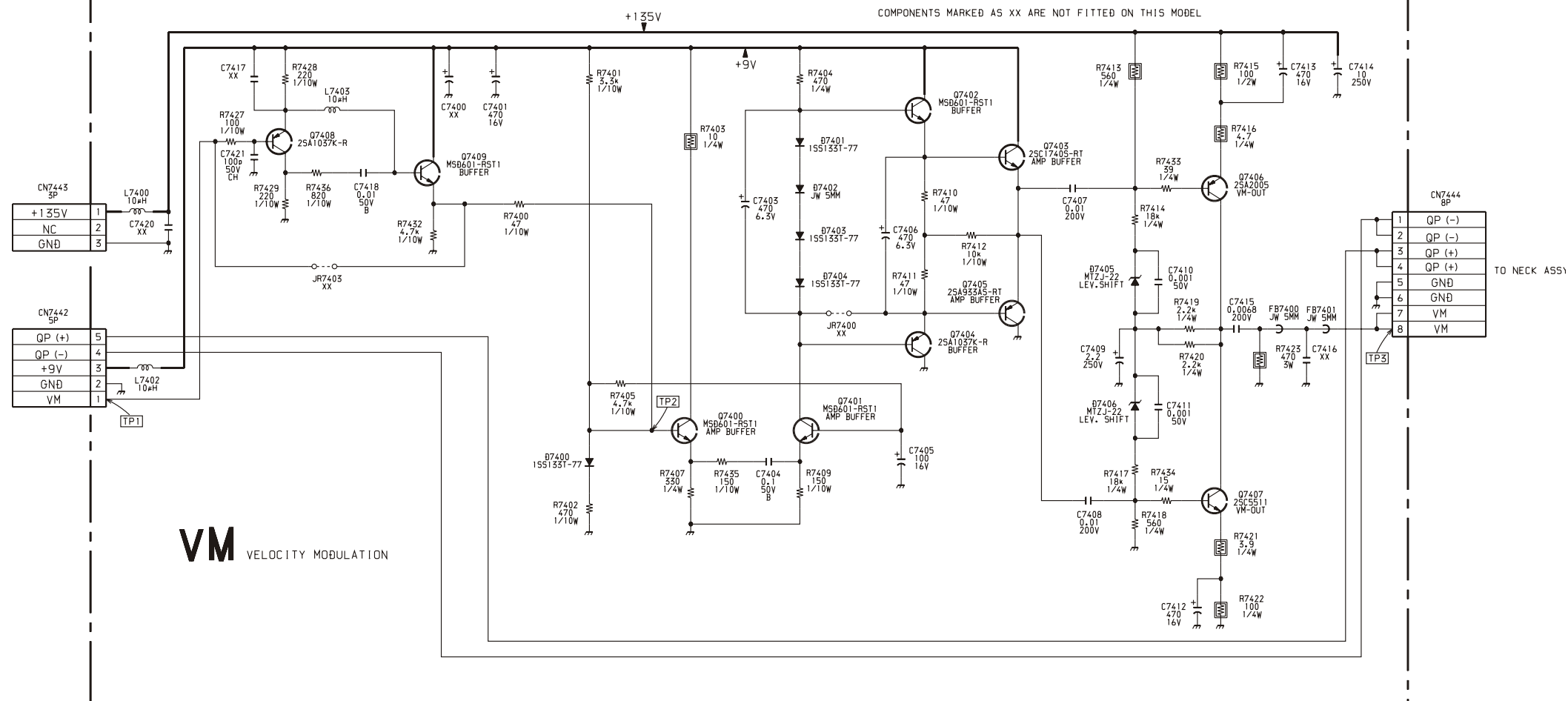

~ VM Board Schematic Diagram ~

G POWER SUPPLY

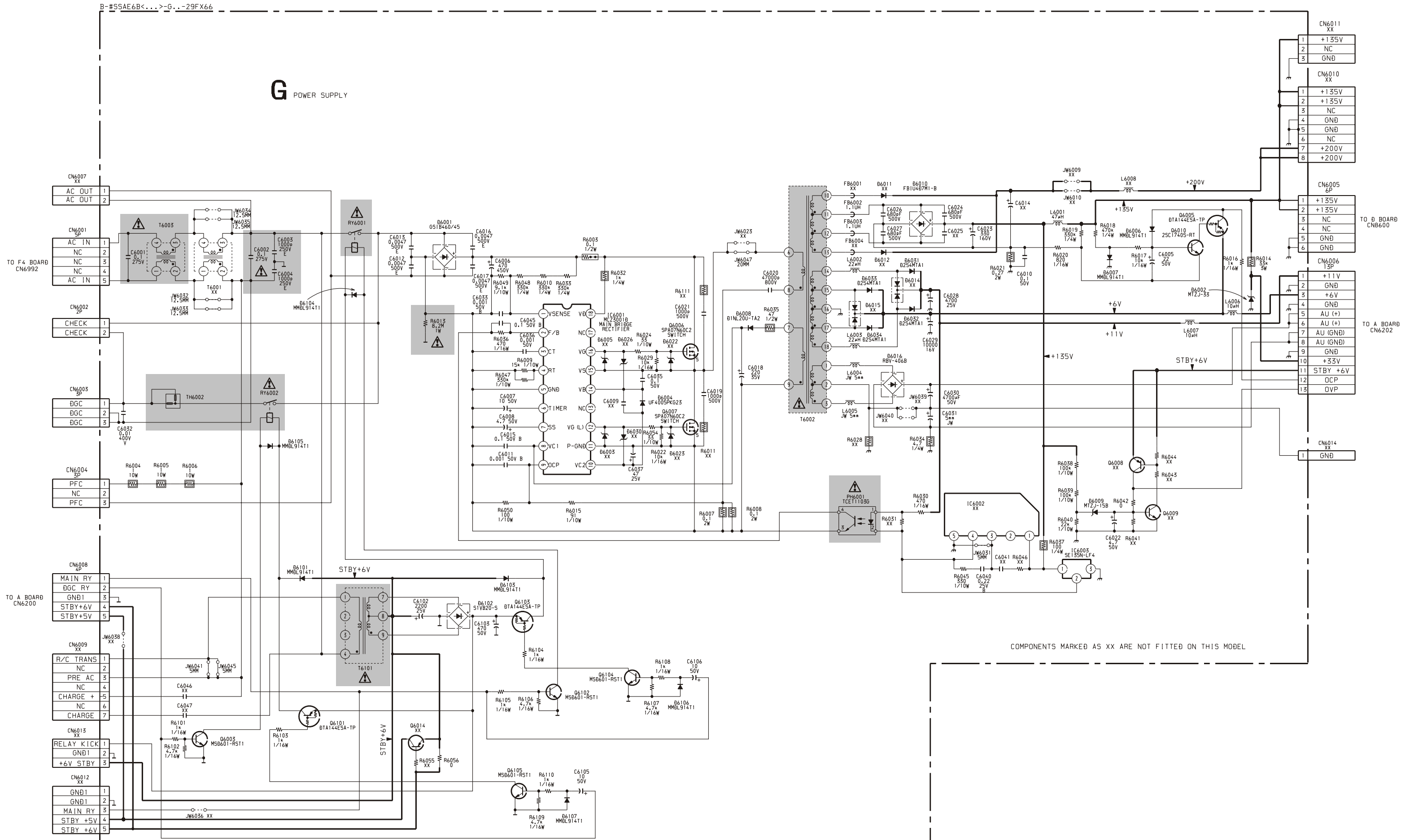

COMPONENTS MARKED AS XX ARE NOT FITTED ON THIS MODEL

A B C D E F G H I J K L M N

1
2
3
4
5
6
7
8
9
10
11

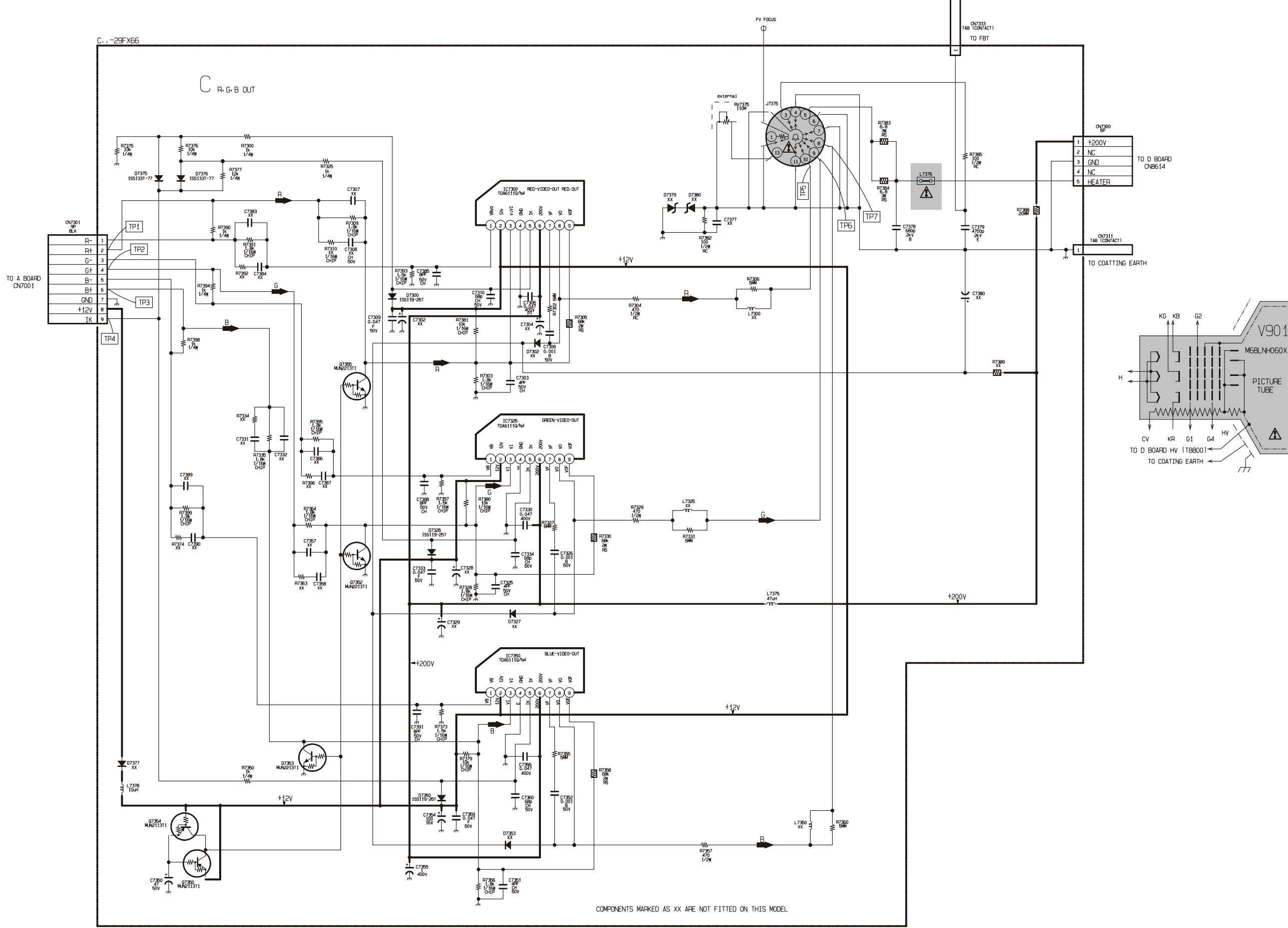

COMPONENTS MARKED AS XX ARE NOT FITTED ON THIS MODEL

~ C Board Schematic [R-G-B Out] ~

B-#SSAE6B<...>-D...-29FX66

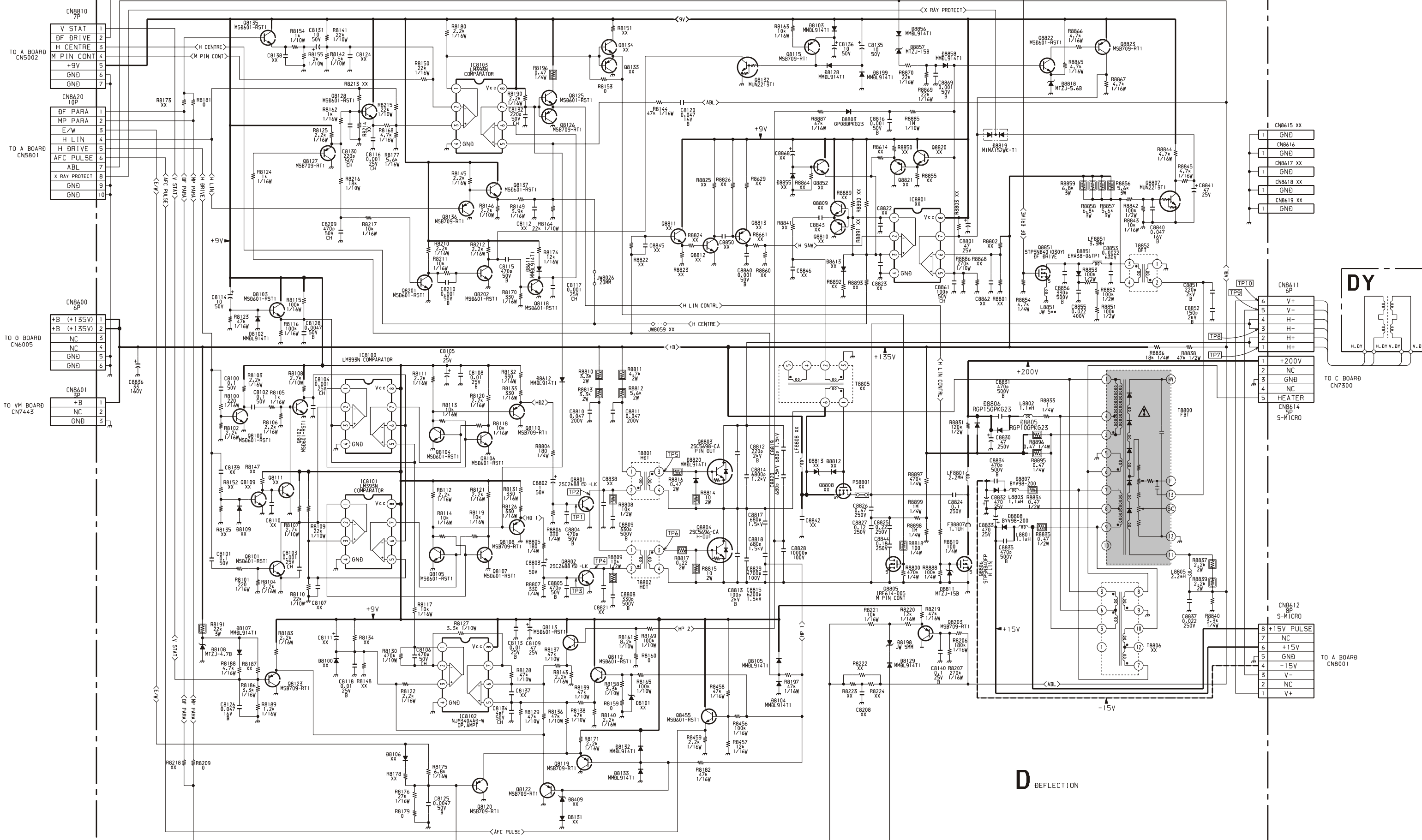

TO A BOARD CN5002

1	V STAT
2	DF DRIVE
3	H CENTRE
4	M PIN CONT
5	+9V
6	GND
7	GND

TO A BOARD CN5801

1	DF PARA
2	MP PARA
3	E/W
4	H LIN
5	H DRIVE
6	AFC PULSE
7	ABL
8	X RAY PROTECT
9	GND
10	GND

TO G BOARD CN6005

1	+B (+135V)
2	+B (+135V)
3	NC
4	NC
5	GND
6	GND

TO VM BOARD CN7443

1	+B
2	NC
3	GND

1	GND
1	GND
1	GND
1	GND
1	GND

1	+200V
2	NC
3	NC
4	NC
5	HEATER

1	+15V PULSE
2	NC
3	+15V
4	-15V
5	GND
6	V-
7	NC
8	V+

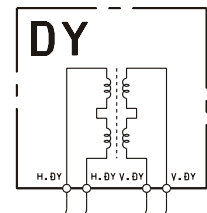

D DEFLECTION

COMPONENTS MARKED AS XX ARE NOT FITTED ON THIS MODEL

M MICRO PROCESSOR

COMPONENTS MARKED AS XX ARE NOT FITTED ON THIS MODEL

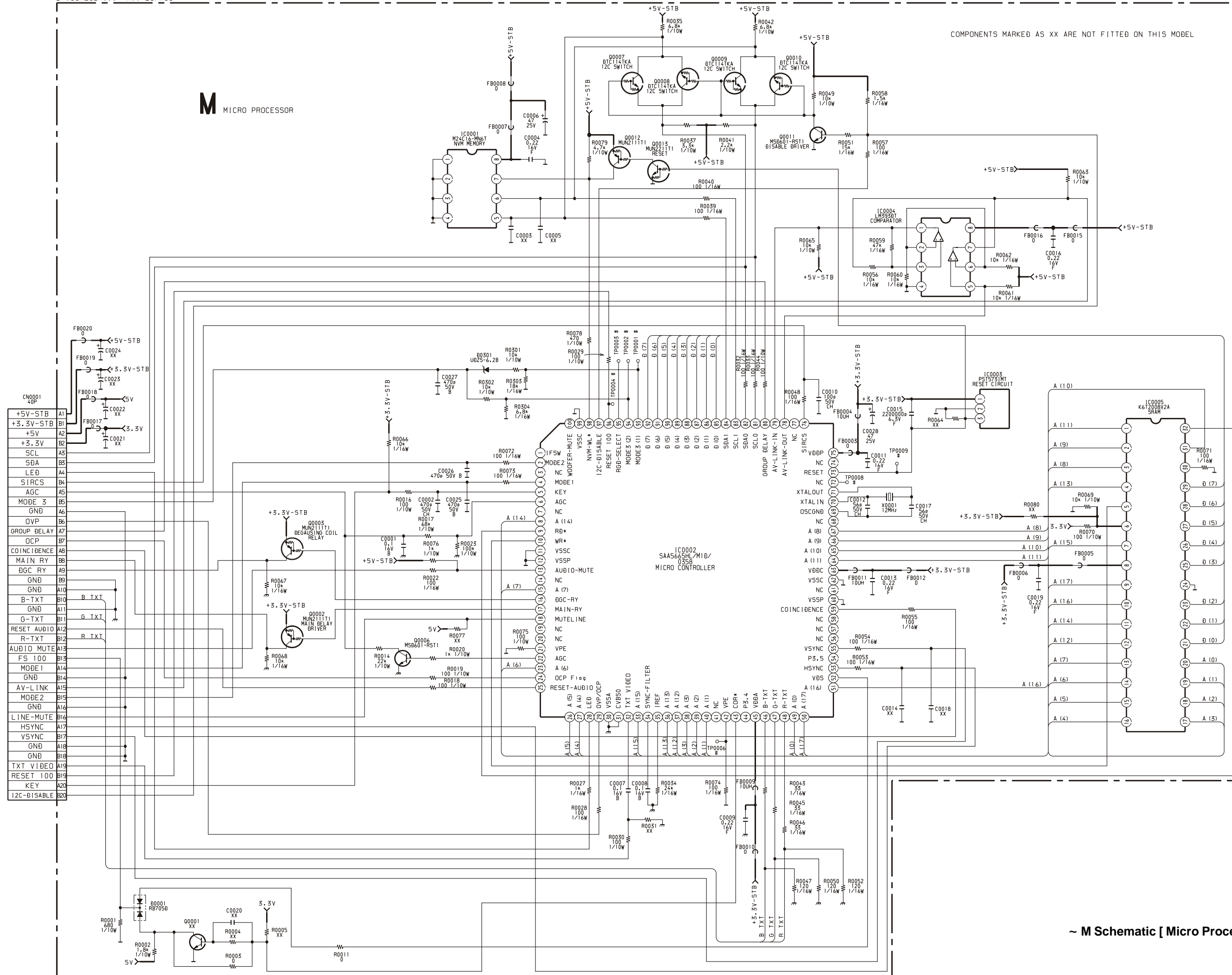

TO A BOARD
CN0101

~ M Schematic [Micro Processor] ~

5-4. SEMICONDUCTORS

CXAB070AP
MCZ3001D

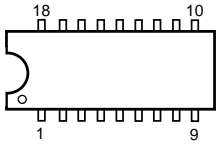

LM318P
LM358N
LM393DT
LM393N
M24C16-MN6T(A)

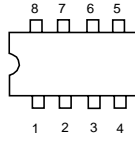

PST573IMT

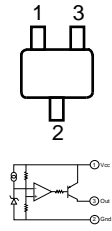

CXA1875AM-T4

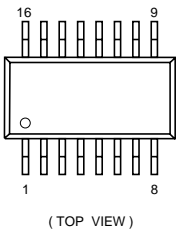

LM78L05ACZ

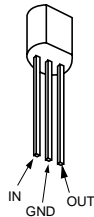

SAA5665HL/M1D/0358

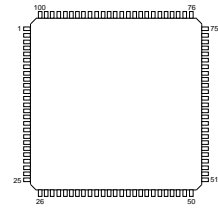

CXA2100AQ-TL

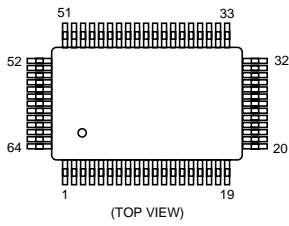

MSP3411G-QA-B10

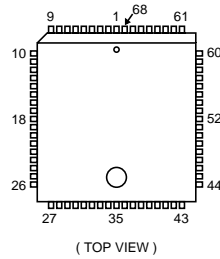

SBX3081-51(30)

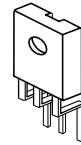

K6T2008V2A-YF70T00

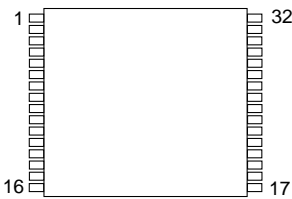

NJM3404AD-W
UPC4558G2

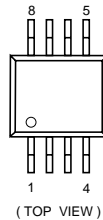

SDA9488X-B23GEG

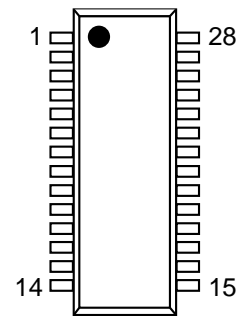

LA6500-FA

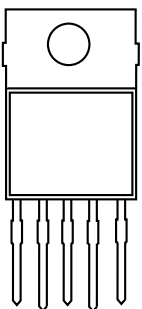

PQ30RV11

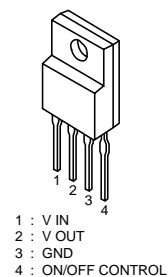

STV9379

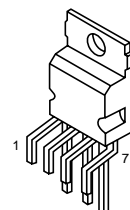

TCET1103G

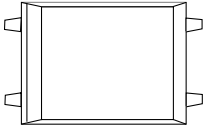

DTA144EK
DTC144TKA-T146
2SA1162-G

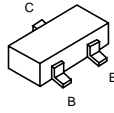

SE135N-LF4

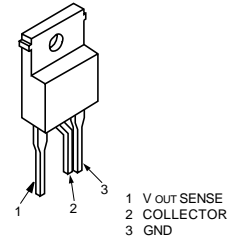

TDA6111Q/N4

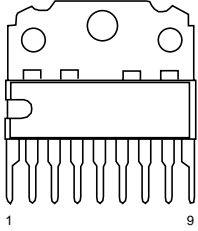

DTA144ESA
2SA933AS-QT
2SC2785-HFE

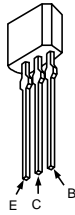

2SA1837(LBS2S0N)

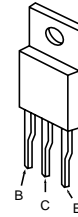

TDA7497

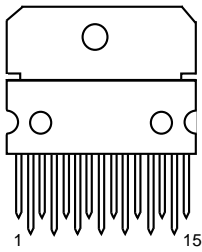

L7809CV/LSY
STP5NB40FP
STP5NB40(030Y)
2SC5698-CA
2S5696-SONY-CA

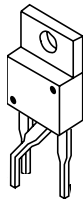

2SB734-34



VPS9402-A32GEG

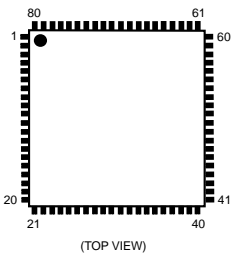

MSB709-RT1
MSD601-RST1
M1MA152WA-T1
UN2111
UN213
2SK2036(TE85L)

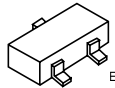

2SC2688(5)-LK

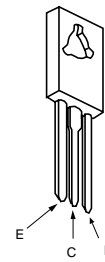

BA12T
BAO33T
IRF614-005
IRF620
SPA07N60C2
2SA2005
2SC5511

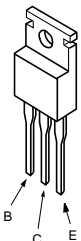

RB705D

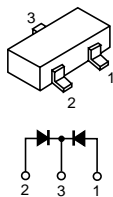

BAS216

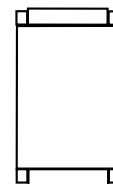

BAS316-115
 MMDL914T1
 UDZSTE-176.2B

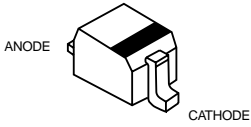

FBIU4D7MA-B
 RBV-406B
 S1VB40

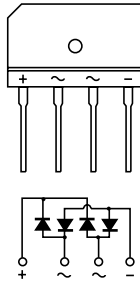

BYV98-200-RAS 15/12

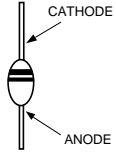

GS1B460/45

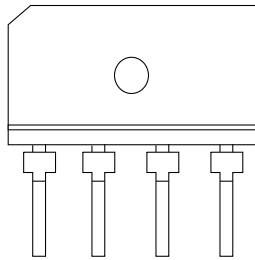

D1NL20U
 EGP20G
 EL1Z
 GP08D
 UF4005PKG23

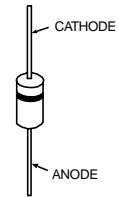

TLHK5190

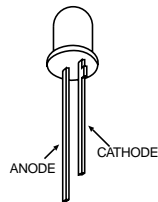

D2S4MTA1

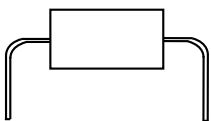

ERA38-06
 ERA85-009
 HZS9.1NB2
 MTZJ-13B
 MTZJ-33B
 MTZJ-3.6A
 MTZJ-4.7C

MTZJ-T-77-22
 RD15ES-B2
 RD39ES-B2
 RD5.6ESB2
 1SS119-25
 1SS133T-77

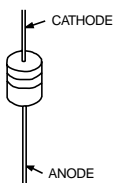

5-5 IC BLOCK DIAGRAMS

A BOARD IC6202/IC6207/IC6205 BA033T/BA12T

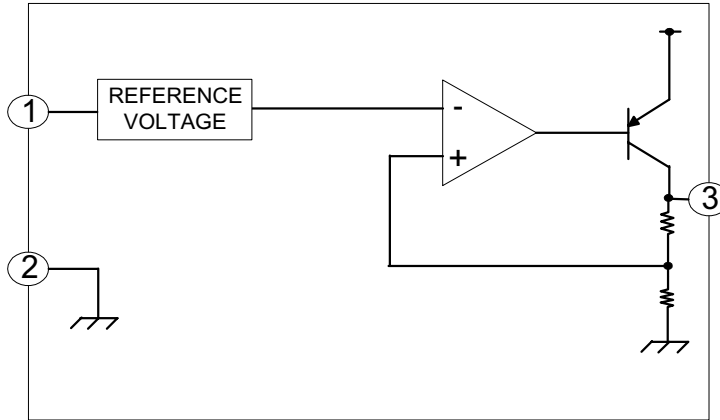

A BOARD IC1201 TDA7497

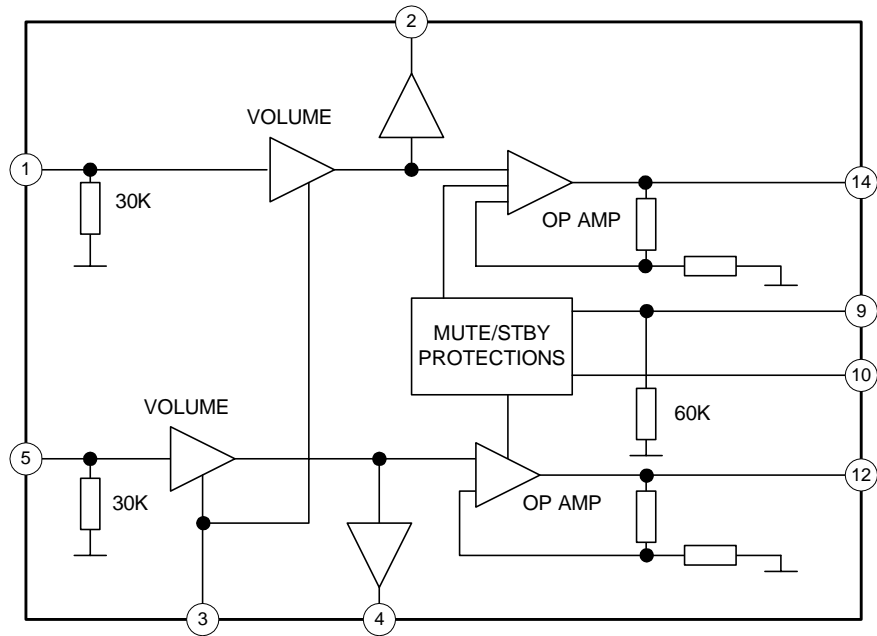

G BOARD IC6001 MCZ3001D

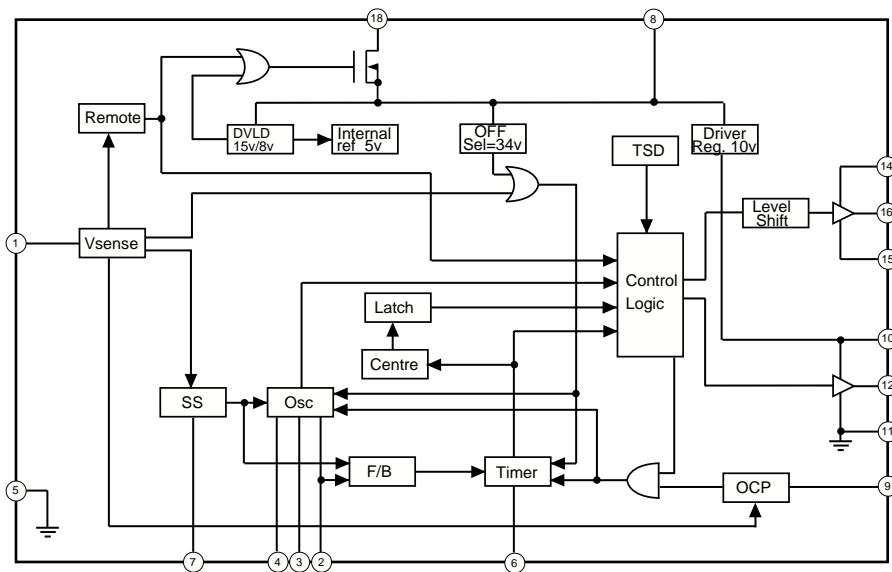

A BOARD IC2000 MSP3411G

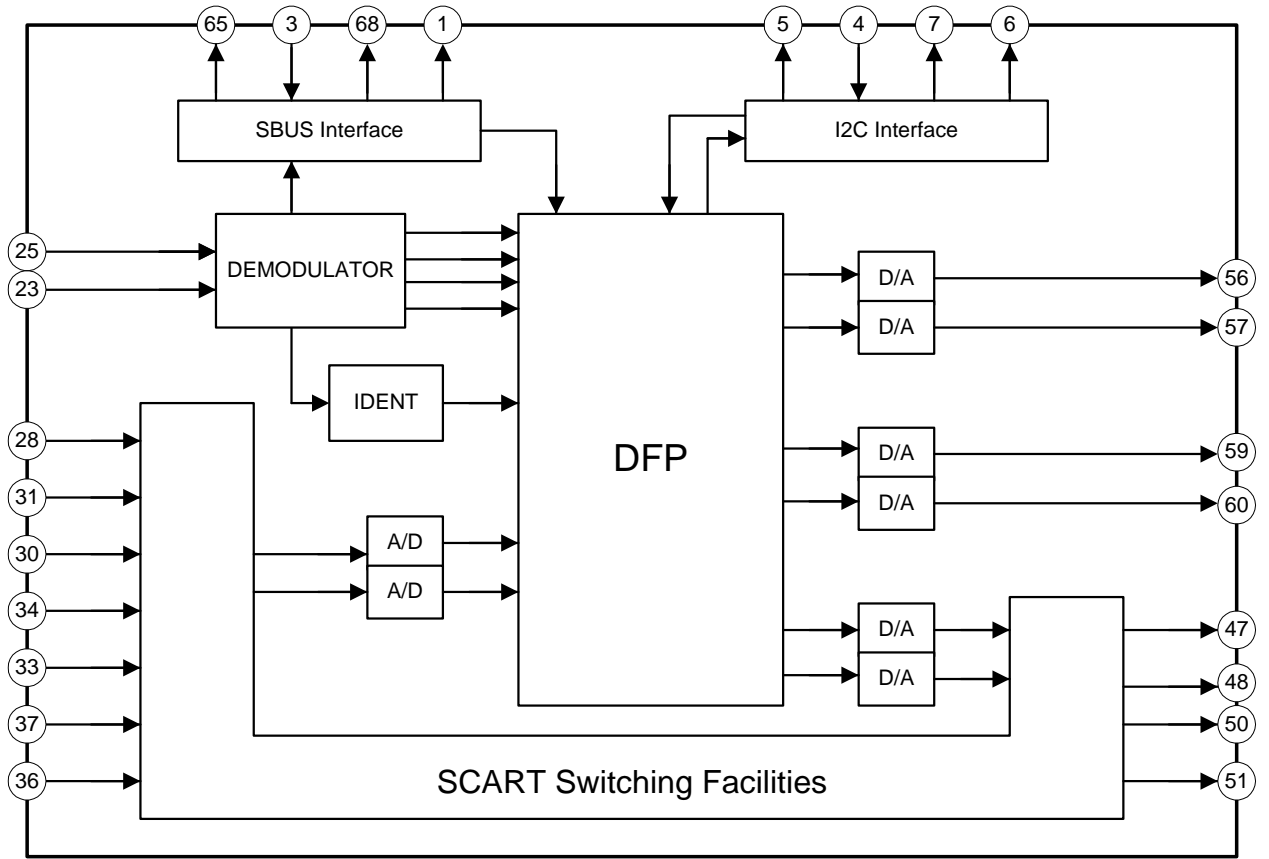

G BOARD IC6003 SE135N-LF4

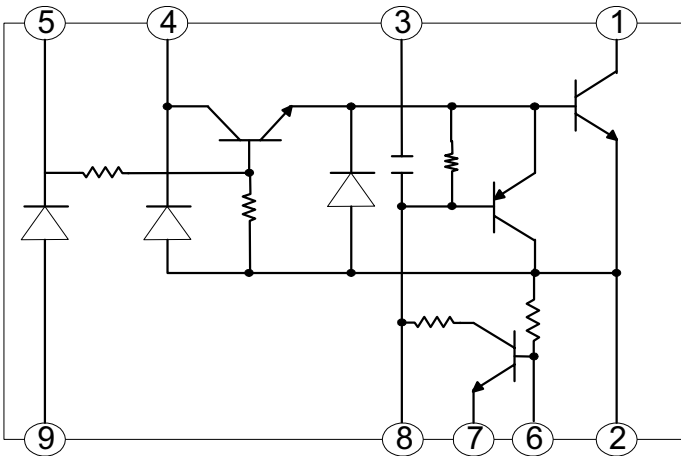

A BOARD IC5301/IC5302 LM393TD

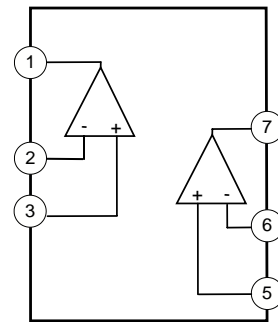

A BOARD IC5400 STV9379

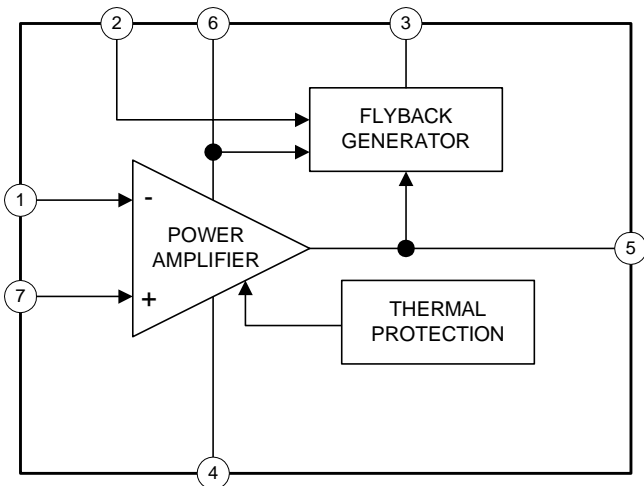

A BOARD IC5300 LM358N

